

# Production Protection



## TSUBAKI EMERSON

OVERLOAD PROTECTION DEVICE

SHOCK RELAY™  
TORQUE GUARD  
TORQUE LIMITER

# Tsubaki Emerson Torque Limiter

Tsubaki Emerson Torque Limiter is the most economical overload protection device, which utilizes the friction mechanism. It can be used with a sprocket, gear, sheave or flange plate as the center member clamped between two friction facings. Tsubaki Emerson has finished bore series with sprocket as the standard product line. It will help to remove processing for the shaft bore and preparing the sprocket.

Tsubaki Emerson Torque Limiter is the easiest to use and the economical overload protection device.



## Torque Limiter

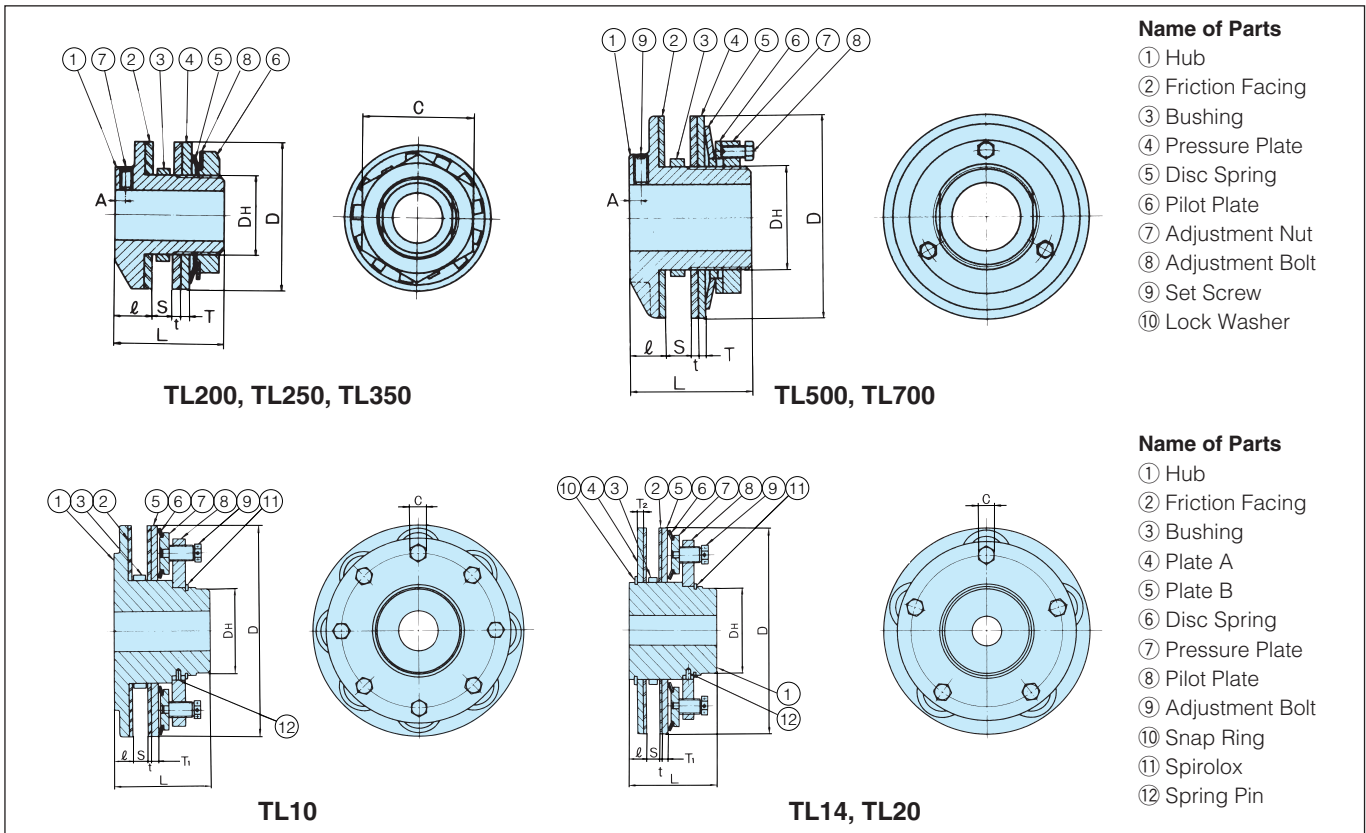

## Torque Limiter Coupling

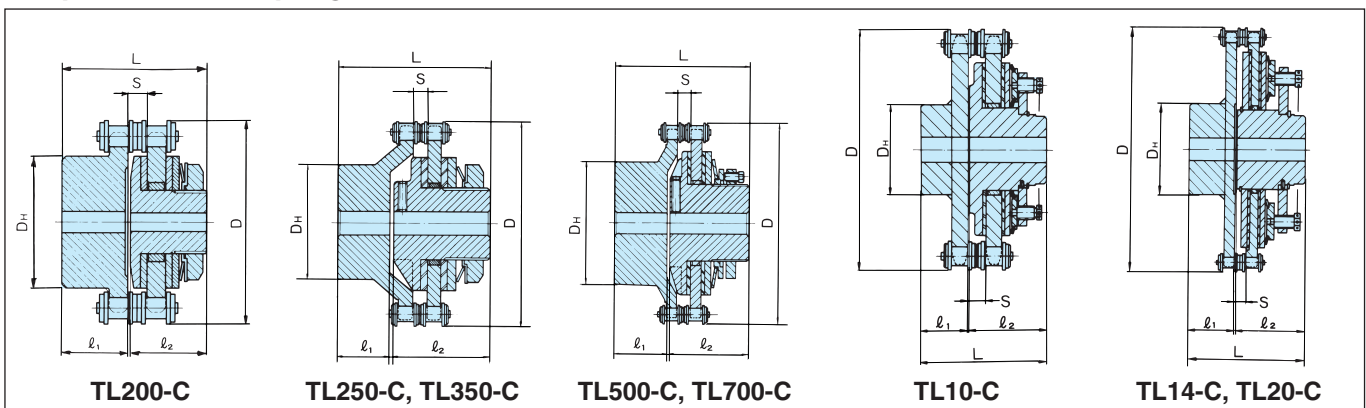

## Capacity and Dimension of Torque Limiter

Dimensions in mm

Model	Torque Range (Nm)	Pilot Bore	Max. Bore	Bushing Length	O.D. of Bushing	Bore for Center Member	D	DH	L	I	T	T1	T2	t	S (max.)	A	C	Mass (kg)
<b>TL200-1L</b>	1.0~2.0	7	14	3.8 6.0	30 <sup>-0.024</sup> <sub>-0.049</sub>	30 <sup>+0.03</sup> <sub>0</sub>	50	24	29	6.5	2.6	—	—	2.5	7	—	38	0.2
<b>TL200-1</b>	2.9~9.8																	
<b>TL200-2</b>	6.9~20																	
<b>TL250-1L</b>	2.9~6.9	10	22	4.5 6.5	41 <sup>-0.010</sup> <sub>-0.045</sub>	41 <sup>+0.05</sup> <sub>0</sub>	65	35	48	16	4.5	—	—	3.2	9	4	50	0.6
<b>TL250-1</b>	6.9~27																	
<b>TL250-2</b>	14~54																	
<b>TL350-1L</b>	9.8~20	17	25	4.5 6.5 9.5	49 <sup>-0.025</sup> <sub>-0.065</sub>	49 <sup>+0.05</sup> <sub>0</sub>	89	42	62	19	4.5	—	—	3.2	16	6	63	1.2
<b>TL350-1</b>	20~74																	
<b>TL350-2</b>	34~149																	
<b>TL500-1L</b>	20~49	20	42	6.5 9.5	74 <sup>-0.05</sup> <sub>-0.10</sub>	74 <sup>+0.05</sup> <sub>0</sub>	127	65	76	22	6.0	—	—	3.2	16	7	—	3.5
<b>TL500-1</b>	47~210																	
<b>TL500-2</b>	88~420																	
<b>TL700-1L</b>	49~118	30	64	9.5 12.5	105 <sup>-0.075</sup> <sub>-0.125</sub>	105 <sup>+0.05</sup> <sub>0</sub>	178	95	98	24	8.0	—	—	3.2	29	8	—	8.4
<b>TL700-1</b>	116~569																	
<b>TL700-2</b>	223~1080																	
TL10-16	400~1240	30	72	12.5 15.5 19.5	135 <sup>-0.085</sup> <sub>-0.125</sub>	135 <sup>+0.07</sup> <sub>0</sub>	254	100	115	23	—	8.5	—	4.0	24	—	19	21
TL10-24	590~1860																	
TL14-10	890~2660	40	100	15.5 19.5 23.5	183 <sup>-0.07</sup> <sub>-0.12</sub>	183 <sup>+0.07</sup> <sub>0</sub>	356	145	150	31	—	13	13	4.0	29	—	27	52
TL14-15	1960~3920																	
TL20- 6	2450~4900																	
TL20-12	4610~9310	50	130	15.5 19.5 23.5	226 <sup>-0.07</sup> <sub>-0.12</sub>	226 <sup>+0.07</sup> <sub>0</sub>	508	185	175	36	—	15	18	4.0	31	—	36	117

## Shaft Bore Size of Finished Bore series

Model	Stock Bore Size (H7) in mm
TL200	11. 12. 14
TL250	12. 14. 15. 16. 18. 19. 20. 22
TL350	18. 19. 20. 22. 24. 25
TL500	22. 24. 25. 30. 35. 38. 40. 42
TL700	35. 40. 42. 45. 50. 55. 60. 63. 63



The key profile should be accordance with DIN 6885.3.

## Capacity and Dimension of Torque Limiter Coupling

Dimensions in mm

Model	Torque Range (Nm)	Max. Running Speed (r/min)	Pilot Bore		Max. Bore		Sprocket	D	DH	L	I <sub>1</sub>	I <sub>2</sub>	S	Mass (kg)
			Sprocket	TL	Sprocket	TL								
<b>TL200-1LC</b>	1.0~2.0	1200	8	7	31	14	RS 40-16T	76	50	55	24	29	7.5	1.0
<b>TL200-1C</b>	2.9~9.8													
<b>TL200-2C</b>	6.9~20													
<b>TL250-1LC</b>	2.9~6.9	1000	13	10	38	22	RS 40-22T	102	56	76	25	48	7.4	1.9
<b>TL250-1C</b>	6.9~27													
<b>TL250-2C</b>	14~54													
<b>TL350-1LC</b>	9.8~20	800	13	17	45	25	RS 50-24T	137	72	103	37	62	9.7	4.2
<b>TL350-1C</b>	20~74													
<b>TL350-2C</b>	34~149													
<b>TL500-1LC</b>	20~49	500	18	20	65	42	RS 60-28T	188	105	120	40	76	11.6	10.0
<b>TL500-1C</b>	47~210													
<b>TL500-2C</b>	88~420													
<b>TL700-1LC</b>	49~118	400	23	30	90	64	RS 80-28T	251	150	168	66	98	15.3	26.0
<b>TL700-1C</b>	116~569													
<b>TL700-2C</b>	223~1080													
TL10-16C	400~1240	300	33	30	95	72	RS140-22T	355	137	189	71	115	26.2	66.0
TL10-24C	590~1860													
TL14-10C	890~2660	200	28	40	118	100	RS160-26T	470	167	235	80	150	30.1	140.0
TL14-15C	1960~3920													
TL20- 6C	2450~4900													
TL20-12C	4610~9310	140	43	50	150	130	RS160-36T	631	237	300	120	175	30.1	285.0

# Tsubaki Emerson Torque Guard

Tsubaki Emerson Torque Guard is the ball detent type overload protection device. It can stop machine immediately when overloaded by using non-contact micro switch. By the Torque meter and Indicator, desired torque can easily be set or adjusted. The non-symmetric arrangement of balls and pockets allows only one engagement position. Once the overload removed, it re-engages automatically by jogging a driving member.

Tsubaki Emerson Torque Guard can protect you from the machine damage and eliminate costly downtime.



## Three kinds of Torque Meter and Indicator

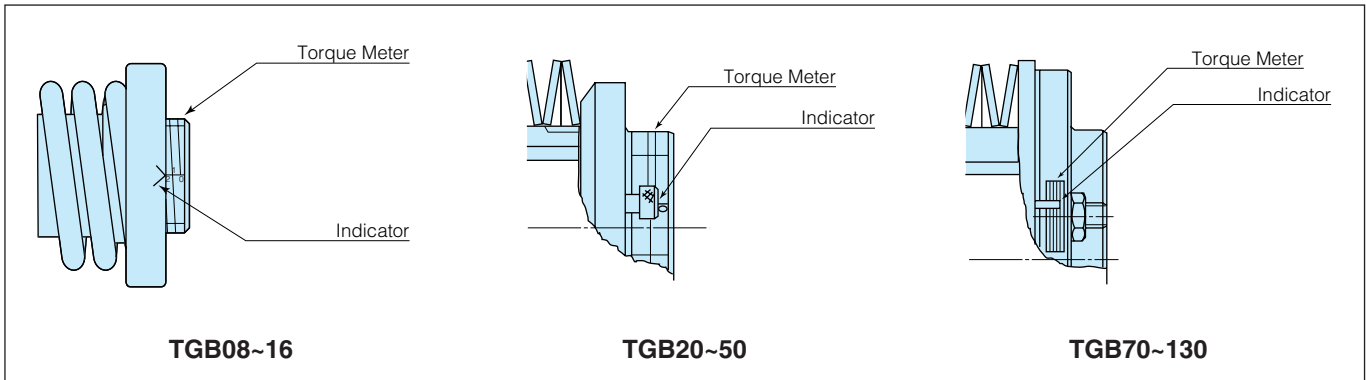

## Specifications of Torque Guard and Torque Guard Coupling

Dimensions in mm

Model	Torque Range (Nm)	Max. Running Speed (r/min)	Color of Disc Spring	Pilot Bore	Max. Bore
TGB 08	L (C)	1200	Yellow	5	8
	M (C)		Blue		
	H (C)		Orange		
TGB 12	L (C)	1000	Yellow	6	12
	M (C)		Blue		
	H (C)		Orange		
TGB 16	L (C)	900	Yellow	7	16
	M (C)		Blue		
	H (C)		Orange		
TGB 20	H (C)	700	Orange	8	20
TGB 30	L (C)	500	Yellow	12	30
	H (C)		Orange		
TGB 50	L (C)	300	Yellow	2	50
	M (C)		Blue		
	H (C)		Orange		
TGB 70	H (C)	160	Orange	32	70
TGB 90	L (C)	120	Yellow	42	90
	H (C)		Orange		
TGB110	L (C)	100	Yellow	52	110
	H (C)		Orange		
TGB130	L (C)	80	Yellow	60	130
	H (C)		Orange		

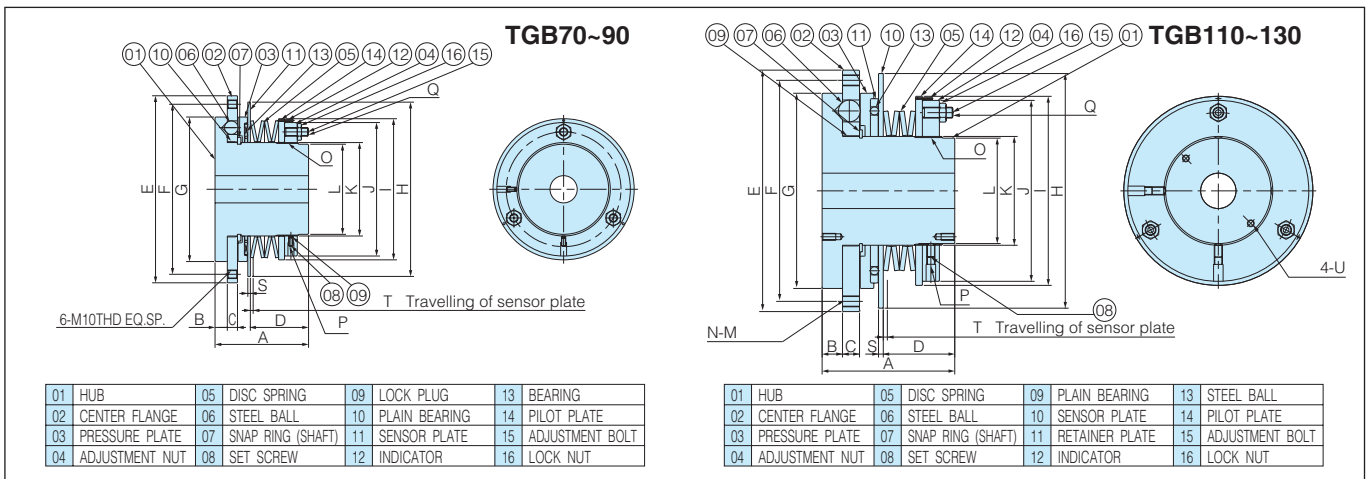
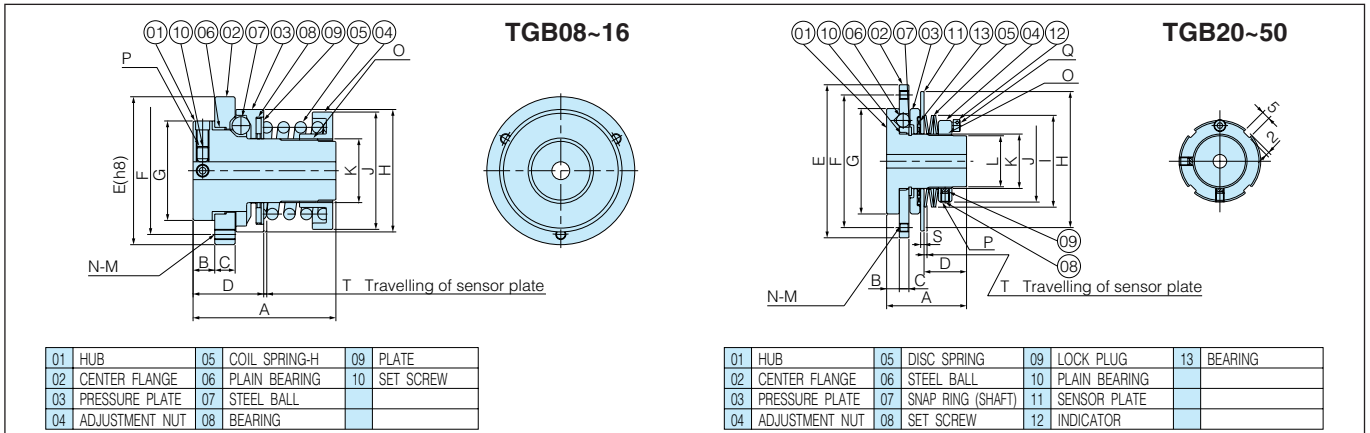

### Dimensions of Torque Guard

Dimensions in mm

Model	A	B	C	D	E (h7)	F P.C.D.	G	H	I	J	K	L	M	N	O Adjust Nut	P Set Screw	Q Adjust Bolt
TGB 08	39	6.5	5	20	40	34	26	33	—	30	15	—	M3	3	M15 × 1	M3 × 4	—
TGB 12	46	8	6	23.5	48	40	32	40	—	35	20	—	M4	3	M20 × 1	M4 × 6	—
TGB 16	55	8.5	8	27.7	58	50	39	48	—	45	25	—	M4	3	M25 × 1.5	M5 × 6	—
TGB 20	47	7.5	5.7	25	90	78	62	82	54	48	32	30	M5	4	M32 × 1.5	M5 × 6	M4 × 8
TGB 30	60	9.5	7	33	113	100	82	106	75	65	45	43	M6	6	M45 × 1.5	M5 × 6	M4 × 10
TGB 50	81	15	8.5	44.8	160	142	122	150	117	95	75	70	M8	6	M75 × 2	M5 × 10	M4 × 14
TGB 70	110	15	12	68.5	220	200	170	205	166	157	110	106	M10	6	M110×2	M5 × 10	M10×28
TGB 90	157	25	22	88.6	295	265	236	290	213	203	130	124	M12	8	M130×2	M10×20	M16×35
TGB110	195	30	25	105	355	325	287	345	278	266	160	155	M16	6	M160×3	M12×20	M16×45
TGB130	230	35	27	130	400	360	319	390	316	304	190	184	M16	8	M190×3	M16×30	M20×60

Model	S	T	U Thread × Depth	W	X	Y Snap Ring	Mass (kg)	Moment of Inertia (×10 <sup>-2</sup> kgf·m <sup>2</sup> )	GD <sup>2</sup> (×10 <sup>-2</sup> kgf·m <sup>2</sup> )
TGB 08	—	0.9	—	—	—	—	0.14	0.0025	0.01
TGB 12	—	1	—	—	—	—	0.24	0.0065	0.026
TGB 16	—	1.2	—	—	—	—	0.44	0.018	0.072
TGB 20	2	1.8	—	5	2	32	0.9	0.058	0.23
TGB 30	2	2	—	6	2.5	45	2.0	0.2	0.79
TGB 50	3	2.7	—	8	3.5	75	5.9	1.21	4.84
TGB 70	3	3.3	—	—	—	110	17.0	6.3	25.2
TGB 90	5.5	5.4	M8 × 16	—	—	130	37.5	33.8	135
TGB110	7	6	M10×20	—	—	160	69.6	91	364
TGB130	7	6.6	M12×24	—	—	190	102	47	688

The table of sprocket, which can be used for the center member of Torque Limiter and fixing to center flange of Torque Guard is shown in page 5.

# Tsubaki Emerson Torque Guard

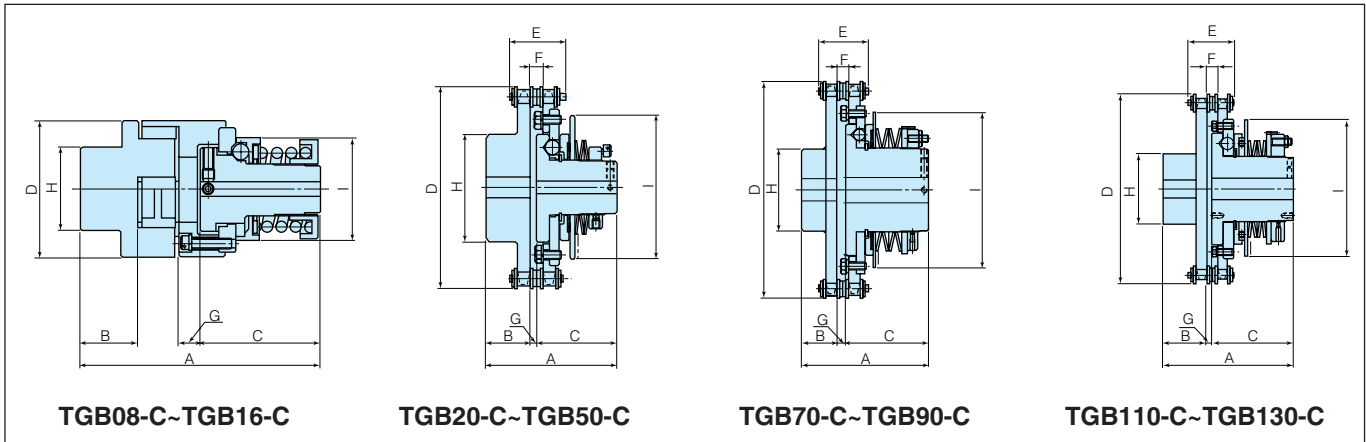

## Dimensions of Torque Guard Coupling

Dimensions in mm

Model	A	B	C	D	E	F	G	H	I	Coupling type and Sprocket size	Mass (kg)	Moment of Inertia ( $\times 10^{-2} \text{kg}\cdot\text{m}^2$ )	GD <sup>2</sup> ( $\times 10^{-2} \text{kgf}\cdot\text{m}^2$ )
TGB 08-C	80	20.6	39	44.5	—	—	7.2	24	13.2	L075A	0.235	0.005	0.02
TGB 12-C	88	19.9	47	53.6	—	—	7.9	32	13.2	L090A	0.380	0.0123	0.049
TGB 16-C	112	27	56	64.3	—	—	10.2	38	18.8	L100A	0.673	0.0324	0.129
TGB 20-C	76	25	47	117.4	32.6	7.4	4	63	—	RS 40-26	2.5	0.313	1.25
TGB 30-C	93	28	60	146.7	40.5	9.7	5	73	—	RS 50-26	4.8	0.948	3.79
TGB 50-C	126	40	81	200.3	51.0	11.6	5	83	—	RS 60-30	12.2	4.43	17.7
TGB 70-C	165	45	110	283.2	64.8	15.3	10	107	—	RS 80-32	32.0	22.43	89.7
TGB 90-C	242	80	157	394.4	78.5	18.2	5	147	—	RS100-36	71.1	117.32	469.29
TGB110-C	303	100	195	473.4	99.2	21.9	8	157	—	RS120-36	130.5	314.15	1255.61
TGB130-C	365	120	230	534.2	127.3	29.1	15	197	—	RS160-30	202.3	632.66	2530.63

Minimum number of teeth for the Center member of Torque Limiter and fixing to the Center flange of Torque Guard.

## Minimum Number of Teeth of Sprocket and Bushing Length for Torque Limiter

Model	Bore of Center Member (mm)	Sprocket Pitch and Number of Teeth																	
		3/8"- #35		1/2"- #40		5/8"- #50		3/4"- #60		1"- #80		1 1/4"- #100		1 1/2"- #120		1 3/4"- #140		2"- #160	
		Minimum No. of Teeth	Bushing Length (mm)	Minimum No. of Teeth	Bushing Length (mm)	Minimum No. of Teeth	Bushing Length (mm)	Minimum No. of Teeth	Bushing Length (mm)	Minimum No. of Teeth	Bushing Length (mm)	Minimum No. of Teeth	Bushing Length (mm)	Minimum No. of Teeth	Bushing Length (mm)	Minimum No. of Teeth	Bushing Length (mm)	Minimum No. of Teeth	Bushing Length (mm)
TL200	30 <sup>+0.03</sup> <sub>0</sub>	20	3.8	16	6														
TL250	41 <sup>+0.05</sup> <sub>0</sub>			20	4.5	17	6.5												
TL350	49 <sup>+0.05</sup> <sub>0</sub>			26	4.5	21	6.5	18	9.5	15	9.5								
TL500	74 <sup>+0.05</sup> <sub>0</sub>					29	6.5	25	9.5	19	9.5								
TL700	105 <sup>+0.05</sup> <sub>0</sub>							33	9.5	26	9.5	21	12.5	18	12.5				
TL 10	135 <sup>+0.07</sup> <sub>0</sub>											29	12.5	24	15.5	22	19.5		
TL 14	183 <sup>+0.07</sup> <sub>0</sub>											39	15.5	33	15.5	29	19.5	26	23.5
TL 20	226 <sup>+0.07</sup> <sub>0</sub>											54	15.5	46	15.5	40	19.5	35	23.5

## Minimum Number of Teeth of Sprocket for Torque Guard

Model	1/4"- #25	3/8"- #35	1/2"- #40	5/8"- #50	3/4"- #60	1"- #80	1 1/4"- #100	1 1/2"- #120	1 3/4"- #140	2"- #160
TGB 08	24	17								
TGB 12	28	20								
TGB 16	32	23								
TGB 20	48	34	26	22						
TGB 30	60	41	32	26	22	18				
TGB 50		57	43	35	30	24	20	17		
TGB 70			58	47	40	31	26	22		
TGB 90				62	52	40	33	28	25	22
TGB110						48	39	33	29	26
TGB130						53	43	37	32	24

# Tsubaki Emerson Shock Relay

Tsubaki Emerson Shock Relay is an extremely reliable electronic device for the protection of machinery from dangerous overloads. While conventional safety devices such as shear pins and thermal relays, the Tsubaki Emerson Shock Relay provides complete protection with accuracy and dependability.

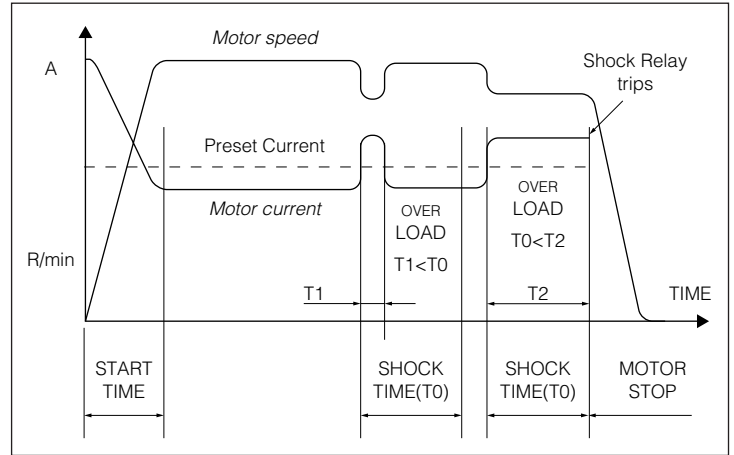
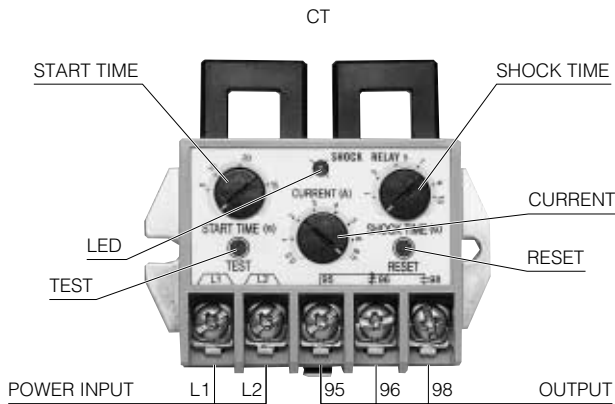

## Specifications of Shock Relay

Function		Model	TSBSS05	TSBSS30	TSBSS60
Motor kW	At 200VAC		0.1~0.75 *1	1.5~5.5	7.5~11
	At 400VAC		0.2~2.2 *1	3.7~11	15~22
Start time			0.2~30s		
Shock time			0.2~10s		
Load current			0.5~5A	3~30A	5~60A
Output relay	Contact rating	A transfer contact 250VAC 3A, Resistive load			
	Minimum allowable load	DC10V, 10mA			
	Status	Normally Energized (self-holding)			
CT Built-in			Yes		
UL Approved			Yes		
cUL			Yes		
CE Conformity			Yes *2		
For DIN rail 35mm			Yes		
Indicator for operation			Yes		
Test function			Yes		
Control voltage			90 to 250VAC 50/60Hz		
Temperature range			-20~+60°C (At Operating)		

\*1 Make sure normal operating current is over 0.5A.

\*2 This apparatus shall not be used in the residential, commercial and light-industrial environment.

## Wiring

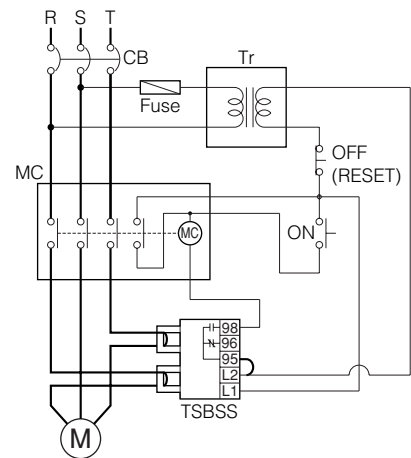

MC : Magnetic contactor ON : Start switch  
OFF : Stop switch Fuse : Fuse Tr : Transformer

\*1. A transformer may be required, depending on the voltage of motor (ie. over 250VAC).

\*2. Output relay is normally energized. When Shock Relay works, it is OFF.

\*3. Two of three phase of the motor are passed through the Shock Relay's CT in the same direction.

## Outline

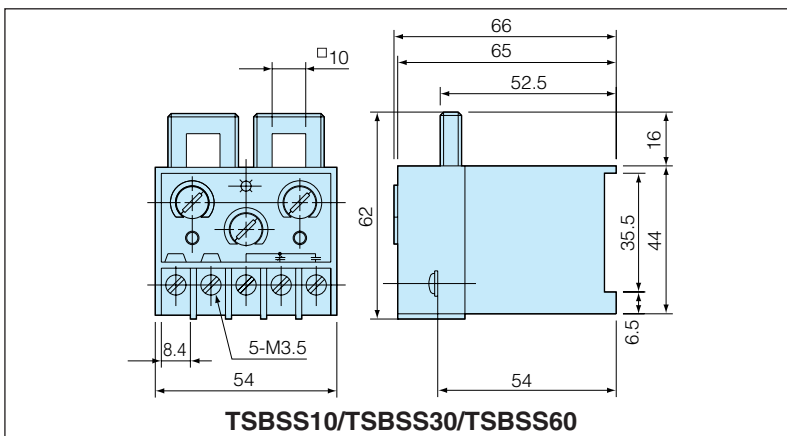

## Mounting frame

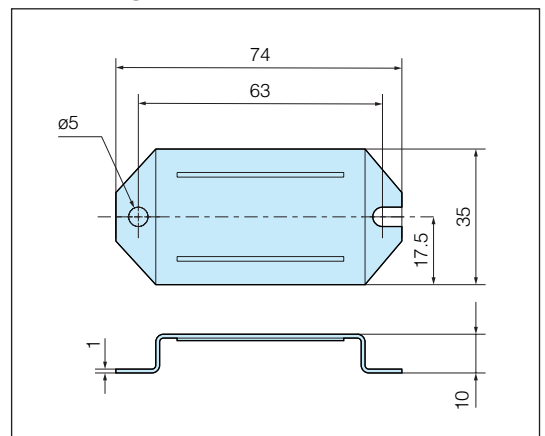

# Tsubaki Overload Protection Devices

## TGM series

Maintenance free and dust prevention type



## TGX series

High precision and high rigidity type



## TGZ series

High speed and ON-OFF clutch capability



Axial overload protection type



## TSBSD series

Digital multi function



Tsubaki has developed various series of Overload Protection Devices to meet any industrial demands. Expect for the series mentioned in these brochures you may need additional technical solutions to comply with your specific application. Please do not hesitate to contact us for advice or further documentation.